



- According to
 - Performance Level (PL) e and category 4 to EN ISO 13849-1: 2008
 - SIL Claimed Level (SIL CL) 3 to IEC/EN 62061
 - Safety Integrity Level (SIL) 3 to IEC/EN 61508
 when connected to a suitable safety module
- Redundant and forcibly guided contacts
- Output: max. 5 NO contacts or 4 NO contacts / 1 NC contact
- 1- or 2-channel connection
- LED indication for operation
- Removeable terminal strips
- Wire connection: also 2 x 1.5 mm² stranded ferruled (isolated), DIN 46 228-1/-2/-3/-4 or 2 x 2.5 mm² stranded ferruled DIN 46 228-1/-2/-3
- Width 22.5 mm

Indication

BG 5929	LED K1/K2:	on, when operating voltage applied
BG 5929/100	LED K1:	on, when relay K1 energized
	LED K2:	on, when relay K2 energized

Notes

The extension module must only be used together with a safety unit e.g. LG 5925) that monitors the feedback circuit Y1/Y2 to achieve (SIL CL) 3 acc. to IEC/EN 62061, SIL 3 to IEC/EN 61508, Performance Level (PL) e and Category 4 to EN ISO 13849-1: 2008.

Approvals and Marking



* see variants

Applications

Contact multiplication of emergency-stop modules and safety door monitors.

Block Diagrams

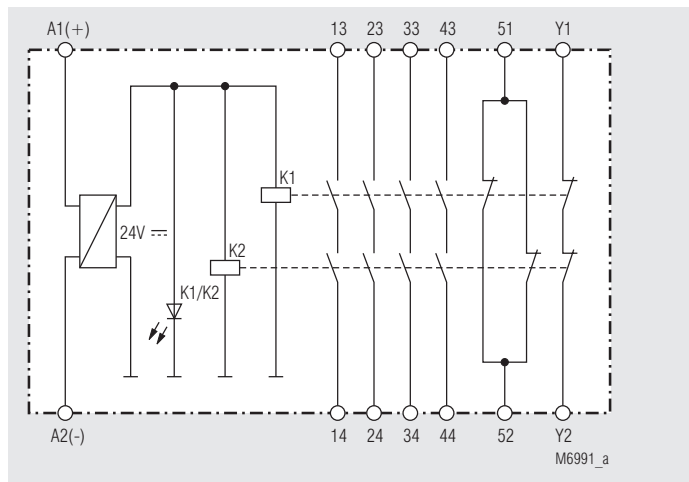

BG 5929.54

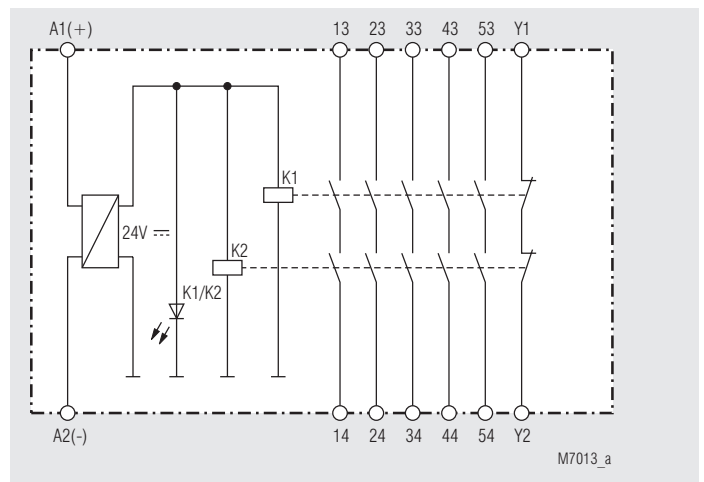

BG 5929.60

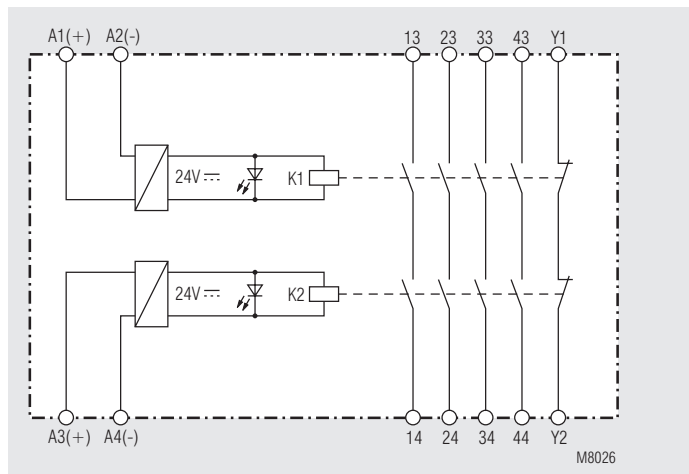

BG 5929.04/100

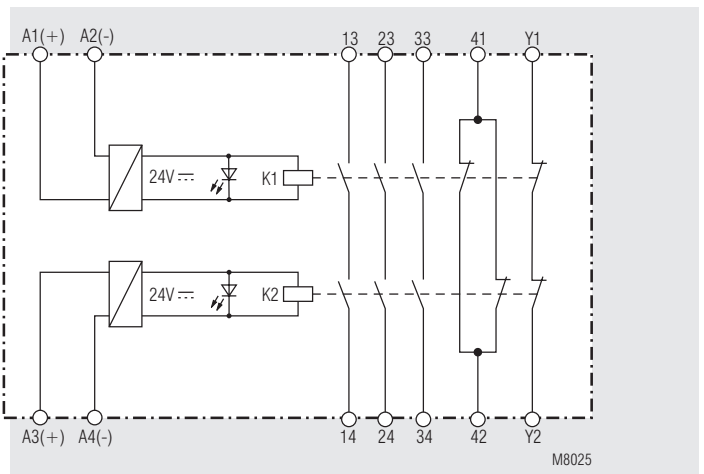

BG 5929.48/100

Circuit Diagrams

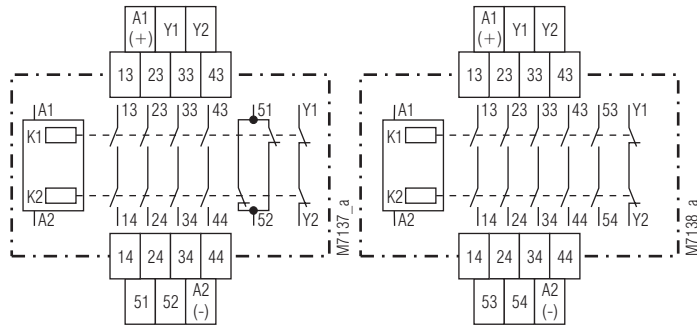

BG 5929.54

BG 5929.60

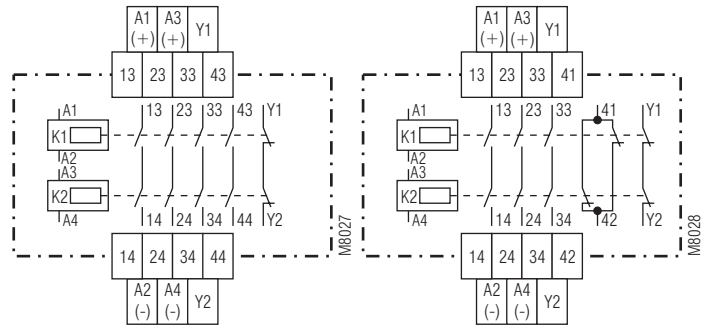

BG 5929.04/100

BG 5929.48/100

Technical Data

Input

Nominal voltage U_N:	AC/DC 24 V
Voltage range:	AC 0.8 ... 1.1 U_N
at 10% residual ripple:	DC 0.9 ... 1.1 U_N
at 48% residual ripple:	DC 0.8 ... 1.1 U_N

Nominal consumption

BG 5929	
AC 24 V:	2.1 VA
DC 24 V:	1.5 W
BG 5929/100	
AC 24 V:	2 x 1.1 VA
DC 24 V:	2 x 0.75 W

Nominal frequency:

50 / 60 Hz

Control current:

BG 5929	
AC 24 V:	60 mA
DC 24 V:	65 mA
BG 5929/100	
AC 24 V:	2 x 40 mA
DC 24 V:	2 x 40 mA

Output

Contacts

BG 5929.60:	5 NO contacts, 1 NC contact for feed back circuit
BG 5929.54:	4 NO contacts, 1 NC contact 1 NC contact for feed back circuit
BG 5929.04/100:	4 NO contacts, 1 NC contact for feed back circuit
BG 5929.48/100:	3 NO contacts, 1 NC contact, 1 NC contact for feed back circuit

Operate time:

max. 20 ms

Release time:

max. 35 ms

Contact type:

relay, forcibly guided

Nominal output voltage:

AC 250 V

Thermal current I_{th} :

see total current limit curve

max. 5 A

Switching capacity

to AC 15		
NO contact:	3 A / AC 230 V	IEC/EN 60 947-5-1
NC contact:	2 A / AC 230 V	IEC/EN 60 947-5-1
to DC 13		
NO contact:	1 A / DC 24 V	IEC/EN 60 947-5-1
NC contact:	1 A / DC 24 V	IEC/EN 60 947-5-1
to DC 13		
NO contact:	4 A / 24 V at 0.1 Hz	
NC contact:	4 A / 24 V at 0.1 Hz	

Electrical life

to AC 15 at 2 A, AC 230 V: 10⁵ switching cycles IEC/EN 60 947-5-1

Permissible switching capacity:

1200 switching cycles / h

Short circuit strength

IEC/EN 60 947-5-1

max. fuse rating:

6 A gL

max. line circuit breaker:

C 8 A

Mechanical life:

10 x 10⁶ switching cycles

General Data

Operating mode:

Continuous operation

Temperature range

operation: - 15 ... + 55 °C

storage: - 25 ... + 85 °C

altitude: < 2.000 m

Technical Data

Clearance and creepage distances

rated impuls voltage / pollution degree: 4 kV / 2 (basis insulation) IEC 60 664-1

EMC

Electrostatic discharge: 8 kV (air) IEC/EN 61 000-4-2

HF-irradiation: 10 V / m IEC/EN 61 000-4-3

Fast transients: 4 kV IEC/EN 61 000-4-4

Surge voltages

between

wires for power supply: 1 kV IEC/EN 61 000-4-5

between wire and ground: 4 kV IEC/EN 61 000-4-5

HF-wire guided: 10 V IEC/EN 61 000-4-6

Interference suppression:

Limit value class B EN 55 011

Degree of protection

Housing: IP 40 IEC/EN 60 529

Terminals: IP 20 IEC/EN 60 529

Housing: Thermoplast with V0 behaviour

according to UL subject 94

Vibration resistance: Amplitude 0.35 mm IEC/EN 60 068-2-6

frequency 10 ... 55 Hz

Climate resistance: 15 / 055 / 04 IEC/EN 60 068-1

Terminal designation:

EN 50 005

Wire connection: 1 x 4 mm² solid or

1 x 2.5 mm² stranded ferruled (isolated)

or

2 x 1.5 mm² stranded ferruled (isolated)

DIN 46 228-1/-2/-3/-4 or

2 x 2.5 mm² stranded ferruled

DIN 46 228-1/-2/-3

terminal screws M 3.5

box terminal with wire protection

DIN rail IEC/EN 60 715

Weight:

180 g

Dimensions

Width x height x depth:

22.5 x 84 x 121 mm

Safety Related Data

Values according to EN ISO 13849-1:

Category::	4	
PL:	e	
MTTF _g :	144,3	a
DC / DC _{avg} :	99.0	%
d _{op} :	365	d/a (days/year)
h _{op} :	24	h/d (hours/day)
t _{Zyklus} :	3.60E+03	s/Zyklus
	≅ 1	/h (hour)

Values according to IEC/EN 62061 / IEC/EN 61508:

SIL CL:	3	IEC/EN 62061
SIL	3	IEC/EN 61508
HFT:	1	
DC / DC _{avg} :	99.0	%
SFF	99.7	%
PFH _D :	3,27E-10	h ⁻¹
T ₁ :	20	a

¹⁾ HFT = Hardware-Failure Tolerance



The values stated above are valid for the standard type.

Safety data for other variants are available on request.

The safety relevant data of the complete system has to be determined by the manufacturer of the system.

Standard Type

BG 5929.60 AC/DC 24 V 50/60 Hz
 Article number: 0050807
 • Output: 5 NO contacts, 1 NC contact for feed back circuit
 • Nominal voltage U_N : AC/DC 24 V
 • Width: 22.5 mm

Variants

BG 5929.___/61: with UL-approval
 BG 5929.___/100: for 2-channel connection, with 2 LEDs

Ordering example for variants

BG5929 . . . /100 AC/DC 24 V 50/60 Hz

_____ Nominal frequency
 _____ Nominal voltage
 _____ Variant, if requested
 _____ Contacts
 _____ Type

Characteristics

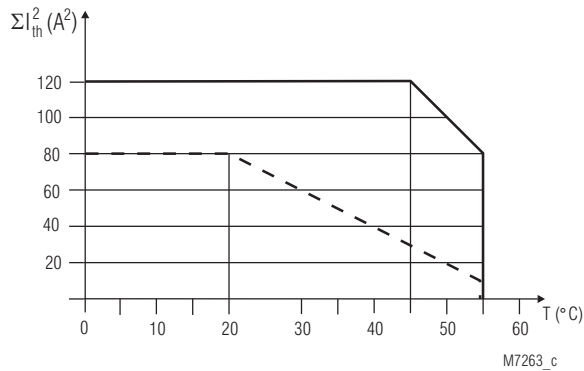

— AC / DC 24 V device mounted on distance with aircondition
 - - - AC / DC 24 V device mounted without distances heated by devices with same load

quadratic total current

$$\sum I_{th}^2 = I_{th1}^2 + I_{th2}^2 + I_{th3}^2 + I_{th4}^2 + I_{th5}^2$$

I_{th1} , I_{th2} , I_{th3} , I_{th4} , I_{th5} : thermal current I_{th} on contact rows

Total current limit curve

Application Examples

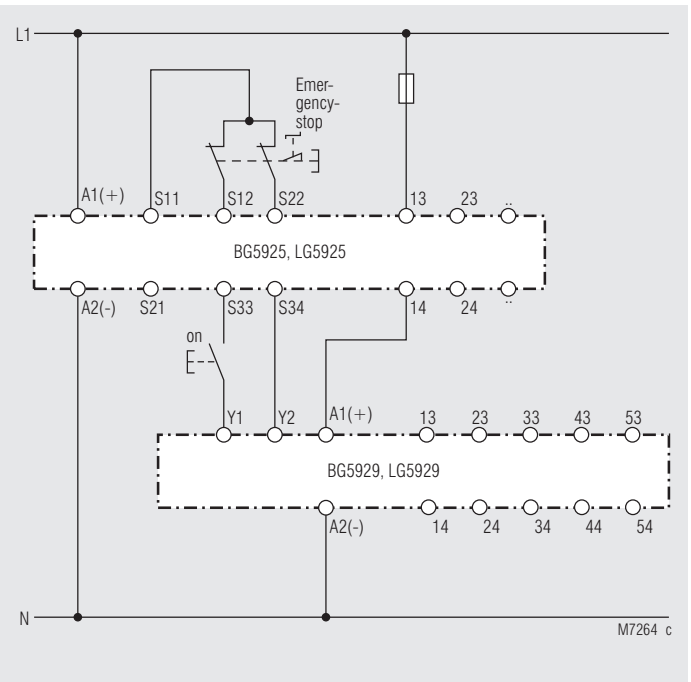

Contact multiplication with 2-channel e-stop and feedback circuit suited up to SIL3, Performance Level e, Cat. 4

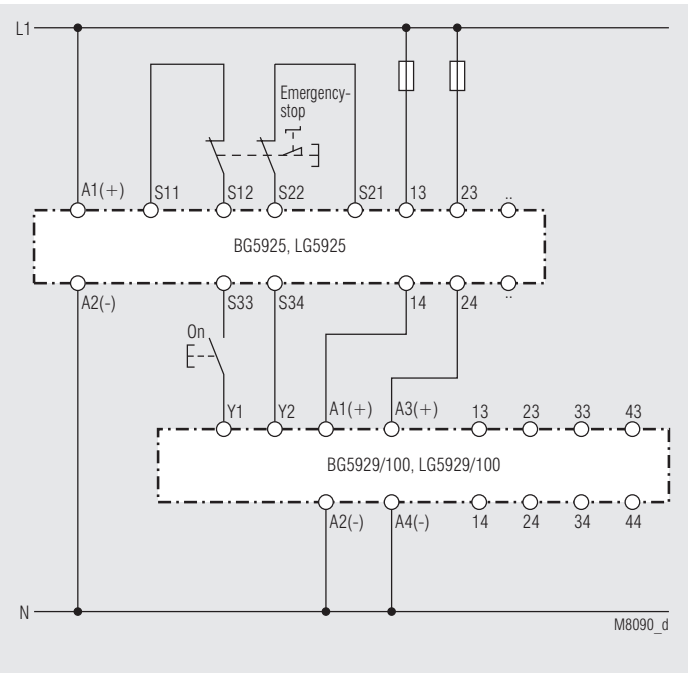

Contact multiplication with BG 5929/100, suited up to SIL3, Performance Level e, Cat. 4

